



2294 Old Highway 431 • Owens Cross Roads, AL 35763  
 Ph: (256)725-2500 or (866)725-8272 • Fax: (877)333-8272  
 WWW.TARALINERS.COM

**SPECIAL LAZY-L LEFT ORDER FORM**

Date: \_\_\_\_\_ Due: \_\_\_\_\_

DEALER

Company: \_\_\_\_\_

Address: \_\_\_\_\_

CITY STATE ZIP

Contact: \_\_\_\_\_ Phone: \_\_\_\_\_

E-Mail: \_\_\_\_\_

DISTRIBUTOR

Company: \_\_\_\_\_

Address: \_\_\_\_\_

CITY STATE ZIP

Contact: \_\_\_\_\_ Phone: \_\_\_\_\_

E-Mail: \_\_\_\_\_

**SHIPPING INSTRUCTIONS**

Branch:  Dealer:  Pick Up:

Ship Via: \_\_\_\_\_

Other: \_\_\_\_\_

**ORDER INFORMATION**

PO #: \_\_\_\_\_

Job Name: \_\_\_\_\_

Price: \_\_\_\_\_

Serial #: \_\_\_\_\_

Stock #: \_\_\_\_\_

Sidewall Pattern: \_\_\_\_\_

Bottom Pattern: \_\_\_\_\_

**MOUNTING**

Beaded:  Overlap:  Overlap Size: \_\_\_\_\_ INCHES

**COMMENTS**

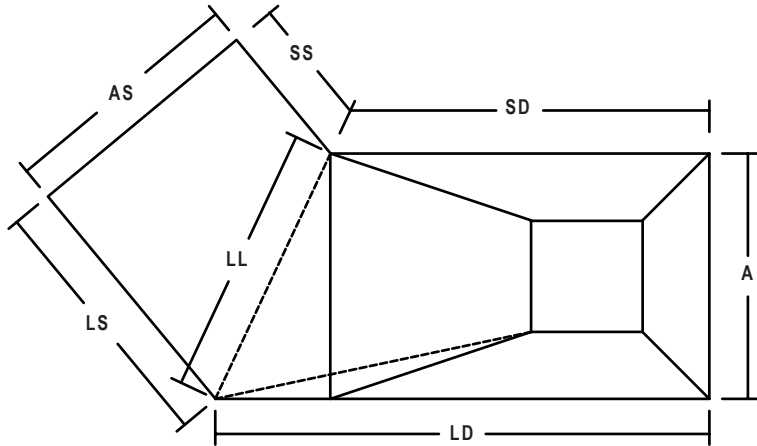

**CORNER TYPE**

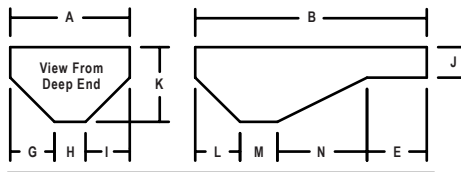
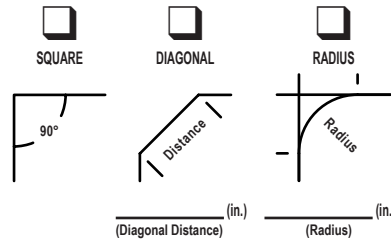

**SAFETY LEDGE**

\_\_\_\_\_ (in.)

**COVE**

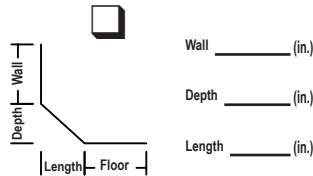

**MEASUREMENTS**

- (A): \_\_\_\_\_ (ft.) \_\_\_\_\_ (in.)    (M): \_\_\_\_\_ (ft.) \_\_\_\_\_ (in.)
- (B): \_\_\_\_\_ (ft.) \_\_\_\_\_ (in.)    (N): \_\_\_\_\_ (ft.) \_\_\_\_\_ (in.)
- (E): \_\_\_\_\_ (ft.) \_\_\_\_\_ (in.)    (AS): \_\_\_\_\_ (ft.) \_\_\_\_\_ (in.)
- (G): \_\_\_\_\_ (ft.) \_\_\_\_\_ (in.)    (LD): \_\_\_\_\_ (ft.) \_\_\_\_\_ (in.)
- (H): \_\_\_\_\_ (ft.) \_\_\_\_\_ (in.)    (LS): \_\_\_\_\_ (ft.) \_\_\_\_\_ (in.)
- (I): \_\_\_\_\_ (ft.) \_\_\_\_\_ (in.)    (SD): \_\_\_\_\_ (ft.) \_\_\_\_\_ (in.)
- (J): \_\_\_\_\_ (ft.) \_\_\_\_\_ (in.)    (SS): \_\_\_\_\_ (ft.) \_\_\_\_\_ (in.)
- (K): \_\_\_\_\_ (ft.) \_\_\_\_\_ (in.)    (LL): \_\_\_\_\_ (ft.) \_\_\_\_\_ (in.)
- (L): \_\_\_\_\_ (ft.) \_\_\_\_\_ (in.)

**Self Check**  
 $G+H+I=A?$   
 $LD+SD+LS+SS+2=B?$   
 $STEP RISERS=J?$

**POOL MANUFACTURER, IF KNOWN:**

DO NOT INCLUDE STEPS ACROSS THE WIDTH OF THE POOL IN THE OVERALL LENGTH "B" MEASUREMENT

**STEP DETAILS**

INDICATE POSITION OF VINYL STEP IF APPLICABLE

1     2     3

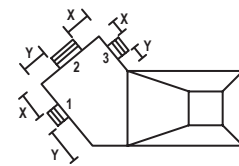

(X) \_\_\_\_\_ (in.)  
 (Y) \_\_\_\_\_ (in.)



**VINYL STEP**

**ROD POCKETS**    **BEADED STEP**  
 YES     NO     YES     NO

**FOAM**

YES     NO

THICKNESS (in.)

**Set Back**

INCHES  
 45°     90°

**Step Corners**

6" RADIUS     90°

FLOOR